

NPD12-12Ah

Valve-regulated lead-acid battery



DEEP CYCLE SERIES

Characteristics

Nominal voltage	12V (6 cell per unit)	
Nominal capacity at 20 hours rate/10.5V (25°C)	12.6Ah	
Capacity (25°C)	10 Hours rate/10.5V	11.7Ah
	1 Hours rate/9.6V	4.7Ah
Terminal type	T1/T2	
Torque	N/A	
Approx. internal resistance (25°C)	20 mΩ	
Dimensions	Length	151±1.5mm (5.94inch)
	Width	98±1mm (3.85inch)
	Height	94±1mm (3.70inch)
	Total height	101±1mm (3.94inch)
Design Life (stand-by)	JIS at 25°C	8 years
	Eurobat at 20°C	6-9 years
Weight	4.05kg (8.92 lbs)±4%	
Nominal operating temperature	25°C±3 (77±5°F)	
Operating temperature range	Discharge	-15°C~50°C (5°F~122°F)
	Charge	-10°C~50°C (14°F~122°F)
	Storage	-20°C~50°C (-4°F~122°F)
Float charging voltage at 25°C	13.5V~13.8V	
Cyclic charging voltage at 25°C	14.5V~15.0V	
Temperature compensation	Float charge	-18 mV/°C/Block
	Cycle charge	-30 mV/°C/Block
Max. charging current (A)	3.6A	
Max. discharge current for 5 seconds	180A	
Self discharge rate (25°C)	≤3%/month	
Battery container ABS UL94-HB	V-0 optional	

Overview

NPP Power Deep Cycle Series are manufactured specifically to provide outstanding performance in deep cycling applications. The batteries are designed using enhanced alloy contents plates and active paste materials.

Dimensions & Terminal Type (mm)

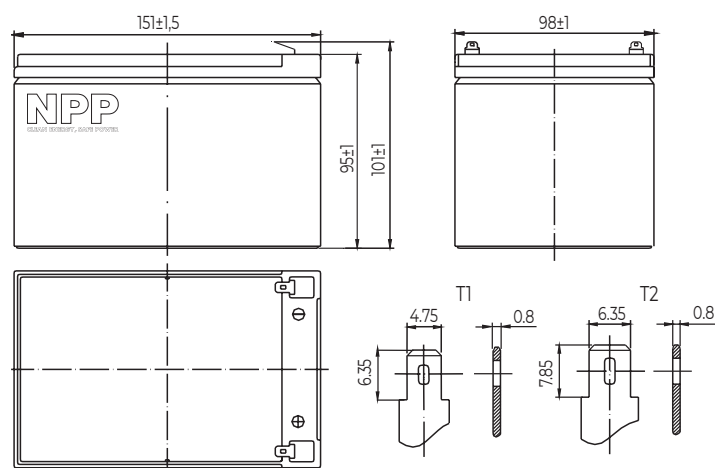

Certification & Compliances



Compliant to: EUROBAT, RoHS, WEEE's and Reach.
Manufactured according to IEC 60896-21 / 22

Construction

Component	Positive Plate	Negative plate	Container	Separator	Electrolyte	Safety valve	Terminal
Raw material	Lead dioxide	Lead	ABS (V-0 opt.)	AGM	Sulfuric Acid	Rubber	Copper

Constant current discharge characteristics at 25°C

(Ampere/battery)

F.V/Time	5min	10min	15min	30min	60min	2hr	3hr	4hr	5hr	10hr	20hr
9.60V	47.8	30.3	23.6	13.3	8.19	4.48	3.10	2.56	2.18	1.18	0.63
9.90V	46.3	29.3	23.1	13.0	8.06	4.45	3.08	2.55	2.17	1.18	0.63
10.2V	44.4	28.1	22.2	12.6	7.86	4.41	3.06	2.53	2.15	1.17	0.63
10.5V	42.5	26.9	21.5	12.3	7.70	4.35	3.04	2.51	2.14	1.17	0.63
10.8V	40.1	25.4	20.3	11.9	7.47	4.24	2.95	2.44	2.07	1.14	0.61

Constant power discharge characteristics at 25°C

(Watts/battery)

F.V/Time	5min	10min	15min	30min	60min	2hr	3hr	4hr	5hr	10hr	20hr
9.60V	533	341	269	153	94.8	52.4	36.8	30.5	26.0	14.2	7.61
9.90V	517	331	263	150	93.4	52.1	36.6	30.3	25.9	14.1	7.58
10.2V	496	317	253	145	91.0	51.6	36.3	30.1	25.7	14.1	7.55
10.5V	474	304	245	141	89.2	50.9	36.1	29.9	25.5	14.0	7.50
10.8V	448	287	232	136	86.5	49.6	35.0	29.0	24.8	13.7	7.35

The above characteristics represent average values and can be obtained within three charge and discharge cycles. The batteries must be fully charged before testing. The data in this document is subject to change without notice and become contractual only after written confirmation. Please contact NPP Power for the latest available version.

NPP Power (Vietnam) Co.,Ltd

Lot A22.3, Road C4, Thanh Thanh Cong Industrial Zone,
An Hoa Village, Trang Bang District, Tay Ninh Province,
Vietnam

Guangzhou NPP Power Co, Ltd.

No.3 Longhui Industrial Road,
Huashan Town, Hadu District, Guangzhou, China
Email: info@npppower.com.cn Tel. +86 20 37887 389